

# PERIMETER SECURITY USING AN ACOUSTIC SENSOR NETWORK

Bhavana Manjunath<sup>†</sup>, Debejyo Chakraborty<sup>‡</sup>

Laboratory for Agile Sensing Research, GWC 431,  
Department of Electrical Engineering, Arizona State University, Tempe, Arizona

Email: <sup>†</sup>bhavana.manjunath@asu.edu, <sup>‡</sup>debejyo@asu.edu

## ABSTRACT

This paper reports the development of an efficient low power, low cost wireless network system for perimeter security that tracks a point target moving through a network of sensors. The system incorporates a sever-client topology with the central processor performing the tracking using acoustic data generated by footsteps. Estimation of the target position is achieved via a particle filtering algorithm used in conjunction with a novel data processing and detection technique designed to operate real-time on the remote sensors. Results are presented from an application to a real-world tracking scenario, demonstrating effective detection and tracking performance.

**Index Terms**— Berkley MICA2 motes, particle filter, time-frequency representation, energy detector, tracker

## 1. INTRODUCTION

Owing to the increased need for the safety of private properties against intruders, perimeter monitoring has recently gained a new level of importance. There are various commercial products for perimeter security available such as Aegis P.C. (a product of GDI), Power fence, outdoor perimeter security systems by Megal Security Systems Ltd. etc.. Until now, the systems that have been used include electric field sensors (EFS) [1] which detect intruders in a field of surveillance by the change in the electric charge flow, infrared (IR) based security systems [2], video motion detectors using closed circuit television (CCTV) [3], and more recently fiber optic sensors (FOS) [4]. However, most of these systems face serious challenges [5] of large size, high power consumption, high cost and high false alarm rate. For instance, systems like EFS have high false alarm rates due to presence of wind and small animals, CCTVs are too expensive to be used in abundance, and FOS may need underground installation which is non-trivial.

In this work, we develop a smart detection algorithm which has a low false alarm probability and provides a reliable tracking system using the state-of-the-art particle filtering [6, 7, 8,

9] method. This novel detection algorithm runs real-time locally on the mote [10, 11, 12] which is our choice of a sensor. It is compact at the size of a matchbox (having all the sensors needed for monitoring with a computing unit not bigger than a thumbnail) and is powered for days together by a pair of AA batteries. Figure 1 shows a schematic of the tracking sce-

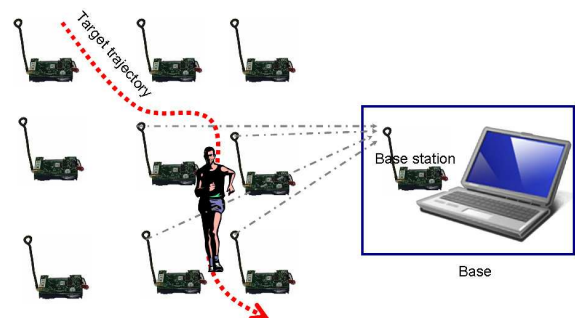

Fig. 1. Target tracking scenario

nario. A target moves along the dotted red line through a grid of regularly placed motes. The motes detect and relay the information regarding the target to the base station as depicted by gray dotted arrows. The base station is also a mote that is hard wired to a computer; we refer to this setup as the *base* henceforth. The target is tracked using the particle filter algorithm running on the commuter at the base.

The remainder of this paper is organized as follows. In Section 2, we start by providing the necessary background on the motes and introduce the particle filter algorithm. Section 3 describes the experimental setup for a real life scenario of interest. The technical details about how the data was processed and the target detected and tracked are discussed in Section 4. Section 5 show the results obtained from our experiment and comments on the performance of the system. We conclude in Section 6 with a short discussion about the future prospects of this technology.

This work was supported in part by the DARPA Integrated Sensing and Processing program through a contract with the Office of Naval Research N00014-04-C-0437

Speed	4 MHz
Flash	128K bytes
SRAM	4K bytes
EEPROM	4 K bytes
Serial Comms	UART
Processor current	5.5 mA active
Radio Frequency	916 MHz
Rated operating voltage	3V
Min. operating voltage	2.4V
A/D	10 bit, 8 channel
word length	8 bits

**Table 1.** MICA2 specifications [10]

## 2. BACKGROUND

### 2.1. The motes

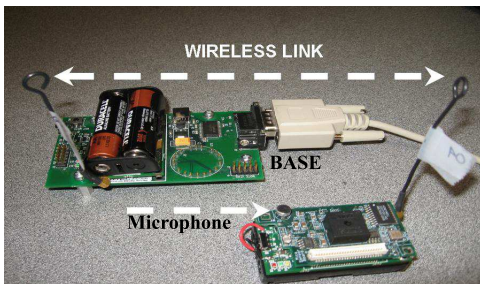

**Fig. 2.** Motes

Berkeley motes, manufactured by Crossbow Technologies Inc. are sensing units characterized by small size (4x2x1 in), low power and cost. Each mote has a processor, a radio, interfacing and data converting modules and other associated hardware on which a sensor board or any other peripheral can be mounted. The type of sensor board used in this experiment has a collection of sensors among which the microphone was used for acoustic sensing. Some basic specifications of the MICA2 [10] motes used in this experiment are summarized in Table 2.1.

The firmware was written in NesC [13], compiled on Tiny OS [13] platform and uploaded through a serial port of the computer using the base. Figure 2 demonstrates the configuration of the base station that was interfaced to the computer. The other mote is the sensor mote. Sensor data was collected, processed and transmitted over the radio to the base station which in turn could relay the information to the computer. These motes were programmed such that they could be turned on/off, and certain programmable parameters could be adjusted remotely [13] without having them reprogrammed.

### 2.2. Particle filter

Particle filtering is a sequential Monte Carlo method for estimating the state of a dynamic system using a sequence of noisy measurements. It is an approximation to the Kalman filter that is needed when the state equations are non-linear or the noise is non-Gaussian. The key idea is to estimate a sequence of unknown parameters,  $x_k$  for  $k = 0, 1, 2, 3, \dots$ , based only on the observed data  $z_k$ . The probability density function at each time instant is represented by point masses or particles [7]. The algorithm has been extensively employed recently in various applications such as sensing and target tracking, computer vision, medical prognosis, communications, model diagnostics, navigation and neural network training [14, 15, 16, 17]. Literature provides instances where these methods lead to results with very high accuracy [9]. Also, from a Bayesian perspective, these methods allow one to compute the posterior probability distributions of interest on-line.

Consider a filtering problem for estimating the state of an evolving unknown vector at discrete time instant  $k + 1$ , based on available information that includes a set of noisy measurements from time 1 to  $k$ , given by  $z_1, \dots, z_k$ .

The state and measurement equations are given by

$$x_k = f(x_{k-1}, v_{k-1}) \quad (1)$$

$$z_k = h(x_k, w_k) \quad (2)$$

where  $v_k$  and  $w_k$  are uncorrelated noise vectors of known distributions, and  $f(\dots)$  and  $h(\dots)$  are known, possibly non-linear functions.

We consider a set of samples (particles)  $x_k^i, \forall i = 1, \dots, N$  with associated weights  $w_k^i$  normalized such that  $\frac{1}{N} \sum_i w_k^i = 1$ . The particles are sampled from an importance distribution given by,  $q(x_k^i | x_{k-1}^i, z_k)$ , and the weights are,

$$w_k^i \approx w_k^i \frac{p(z_k | x_k^i) p(x_k^i | x_{k-1}^i)}{q(x_k^i | x_{k-1}^i, z_k)} \quad (3)$$

The posterior density can be approximated by [6]

$$p(x_k | z_k) \approx \sum_{i=1}^N w_k^i \delta(x_k - x_k^i) \quad (4)$$

In our application, a constant velocity model is assumed for the state equation and the energy measurements from the motes are modeled for the measurement equation which will be discussed in Section 4.3

## 3. EXPERIMENTAL SETUP

The block diagram in Figure 3 shows the basic operational software and hardware modules of a wireless sensor as used in the application described in this paper.

Motes can be programmed to work as a transmitter or a receiver. The transmitter mote is described in Figure 3(a). The

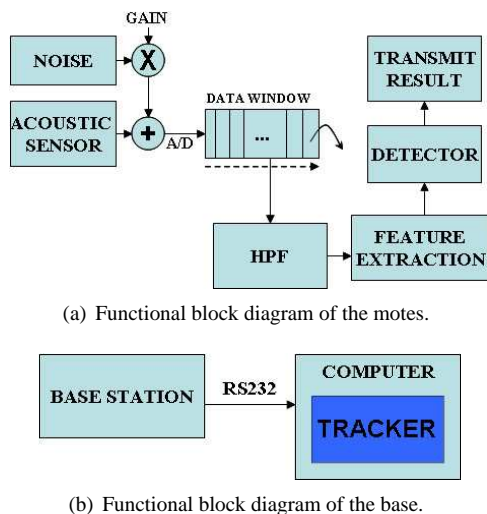

Fig. 3. Schematic block diagram of functional units.

acoustic signal and the noise transduced from the microphone were digitized into 1 byte of information using an analog to digital converter (A/D). This byte was queued in the data window and filtered through a high pass filter (HPF) as described in Section 4.1. Features were extracted from successive filtered windows sliding over one sample at a time and were collectively used by the detector block to detect the presence of a footstep in a stream of data. The feature extraction and detection blocks are discussed in Section 4.2. Upon detection, the information was transmitted to the base station.

A functional block diagram of the base is demonstrated in Figure 3(b). The base station was a mote programmed to receive the information sent by other motes and relay the same to the computer. A parallel port was chosen to communicate the information to the computer where particle filter was executed to track the movements of the target in a field of wireless sensors.

## 4. DATA PROCESSING, DETECTION AND TRACKING

### 4.1. Digital data processing

The byte of information acquired from the A/D was queued in a buffer of pre-defined window length  $N$ . This buffer array was the window of analysis. As depicted in the block diagram in Figure 3(a), the incoming data sample was accommodated into the buffer by shifting all the previous samples and discarding the oldest one. Since the order of the samples in the buffer did not matter, the implementation of a circular buffer reduced the number of move operations from  $N$  to zero. The oldest sample in the sequence was replaced by the most recent one. The overhead of running one counter, to keep a track of which was the oldest sample in the sequence

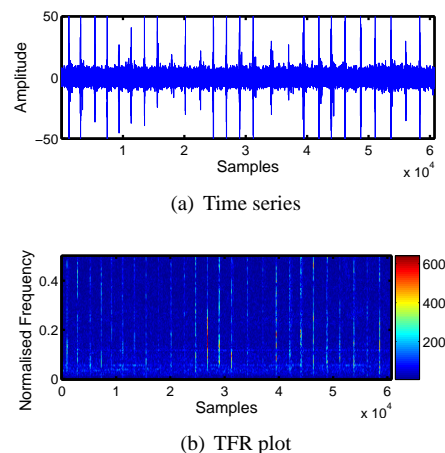

Fig. 4. Footstep data from walking in boots on concrete at 2 feet from sensor

was negligible compared to  $N$  move operations. Digital data processing mainly depends on the acoustic signature of a footstep that is a function of the ground, the footwear, pace and the style of walking. For our analysis, we have chosen the sound made by boots on a concrete ground as shown in Figures 4 and 5. More examples of footstep data can be obtained from [18]. Figure 4(b) is a spectrogram time-frequency repre-

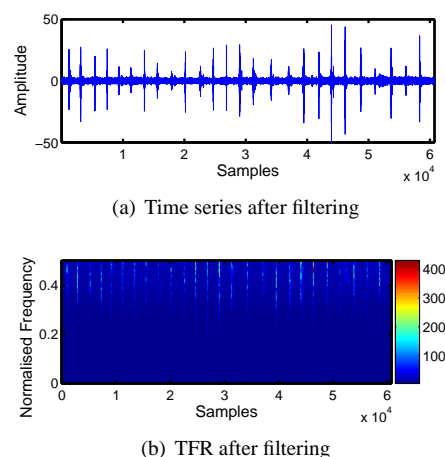

Fig. 5. Filtered footstep data from walking in boots on concrete at 2 feet from sensor

sentation (TFR) [19, 20] of footsteps, and it demonstrates the fact that footstep data is a high frequency information at the given nyquist range. The low frequency component is mainly noise due to speech, wind and humming of electronics. The TFR of the filtered signal is shown in Figure 5(b). Comparing the time series before and after filtering in Figures 4(a) and 5(a), we can observe that the noise in the signal got attenuated rendering more prominent peaks corresponding to the occurrence of footsteps. However, speech with consonants like 't'

and 'd' which has footstep like signature posed a challenge.

The finite impulse response (FIR) high pass filter coefficients had to be 8-bit integers and were designed as in Equation (5) in order to be implemented on the motes.

$$h = \{1, -7, 21, -35, 35, -21, 7, -1\}/2^7 \quad (5)$$

The magnitudes of  $h$  form the 8th level of Pascal's triangle [21] and the scaling could be implemented using a right shift operation.

#### 4.2. Footstep energy detector

The energy detector incorporated an energy detection algorithm with a sophisticated feature extraction technique to make a detection. It is described in the algorithm as follows.

1. The window energy was calculated as  $E = \sum_{k=0}^{N-1} |s[k]|^2$  where  $s[k]$  is the filtered sample at time  $k$  and was compared with a set threshold  $\gamma$ .
2. A count ( $\mathbb{C}$ ) of the number of successive samples for which  $E > \gamma$  was kept. This gave an idea of the time duration of high energy signal recorded.
3. A footstep data was experimentally determined to have a lower bound ( $B_l = 200$ ) and an upper limit ( $B_u = 500$ ) samples.
4. If  $\mathbb{C} < B_l$  and  $E < \gamma$ ,  $\mathbb{C}$  was initialized; this was interpreted as high amplitude measurement noise.
5. If  $\mathbb{C} > B_u$  and  $E > \gamma$ ,  $\mathbb{C}$  was initialized when  $\gamma < E$  was true; this was interpreted as high amplitude ambient noise, probably speech or wind.
6. If  $B_l \leq \mathbb{C} \leq B_u$  and  $E < \gamma$  for at least 500 successive samples, then it was considered as a valid footstep and  $\mathbb{C}$  is reset.
7. If  $E < \gamma$  is true for a duration less than 500 samples, it was considered a part of the same footstep signal (probably as echo) and was counted as one footstep and not two successive footsteps separated by a very short time. This kind of walking pattern was observed with some men wearing boots and women wearing high heels on a hard ground like concrete.

The parameters  $\gamma$ ,  $B_u$ ,  $B_l$  and sensor oriented firmware parameters like mic gain can be varied in the program to suit the conditions where the hardware is deployed. These measures were taken to minimize the false alarm at the cost of a considerable amount of missed detections. Varying the mentioned parameters would affect the performance of the detector.

The detection and feature extraction algorithm has been summarised using data from boots at a distance of 4 feet from

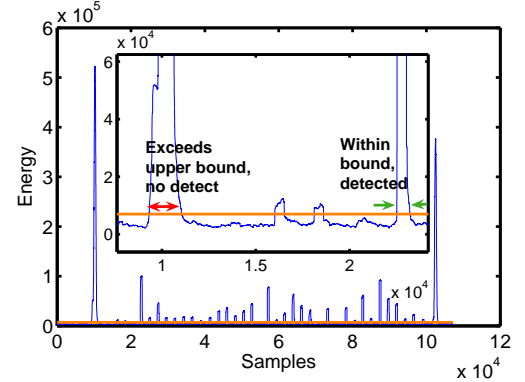

Fig. 6. Energy levels of footstep data at each time window

the sensor in Figure 6. The outer plot shows the energy as the window shifted over the data samples. The inner plot is the zoomed in version of the entire plot. In the bounds of the inner plot, 3 footsteps were detected and the speech signal occurring around sample number  $1 \times 10^4$  was omitted. The horizontal solid line shows the threshold level  $\gamma$  set for this simulation. Increasing  $\gamma$  would cause the footsteps with low energy to be missed. Altering of  $|B_u \sim B_l|$  would result in detecting the speech signal as a valid footstep and missing most of the footsteps.

Note that 32-bit time stamped energy values were relayed to the base station along with identification information of every mote that detected a footstep. At a given time instance, from the information received the computer could localize a target in the two-dimensional cartesian system. This information was used by the particle filter tracker described in the next section to predict and track the moving target.

#### 4.3. Particle filter tracker

An eight bit particle filter tracker was implemented and the performance was evaluated via simulation. The problem involved estimating position  $(x, y)$  at time  $k$  using the state information at  $k - 1$  and all the observation information till time  $k$ .

The state vector consisting of positions  $(x, y)$  and velocities  $(\dot{x}_k, \dot{y}_k)$  is given by,

$$\begin{bmatrix} x_k \\ \dot{x}_k \\ y_k \\ \dot{y}_k \end{bmatrix} = \begin{bmatrix} 1 & \Delta t & 0 & 0 \\ 0 & 1 & 0 & 0 \\ 0 & 0 & 1 & \Delta t \\ 0 & 0 & 0 & 1 \end{bmatrix} \begin{bmatrix} x_{k-1} \\ \dot{x}_{k-1} \\ y_{k-1} \\ \dot{y}_{k-1} \end{bmatrix} + \sqrt{q} \begin{bmatrix} \frac{\Delta t^3}{3} & \frac{\Delta t^2}{2} & 0 & 0 \\ \frac{\Delta t^2}{2} & \Delta t & 0 & 0 \\ 0 & 0 & \frac{\Delta t^3}{3} & \frac{\Delta t^2}{2} \\ 0 & 0 & \frac{\Delta t^2}{2} & \Delta t \end{bmatrix}^{1/2} \begin{bmatrix} \nu_{k-1}^1 \\ \nu_{k-1}^2 \\ \nu_{k-1}^3 \\ \nu_{k-1}^4 \end{bmatrix} \quad (6)$$

where  $\Delta t$  is the difference between two consecutive time steps

and also represents the sampling period, and  $\sqrt{q}$  is a factor used to control the intensity of the process noise. This constant velocity model was assumed for the state transition. The observation in our case was the acoustic energy of the footstep data.

The measurement vector modeled by [22] is given by,

$$\text{Energy} = \frac{S_0}{d^n} + b. \quad (7)$$

where,  $S_0$  is the source energy at a distance of one meter, and  $b$  is a bias related to noise in the measurements.  $d$  is the distance between the sensor and the tracker at time  $k$ . The non-linear relation between the measurement and the state vectors is given by

$$z_k = \frac{S_0}{(\sqrt{x_k^2 + y_k^2})^n} + b + \sqrt{R}w_k \quad (8)$$

where  $R$  denotes the measurement noise covariance matrix and  $w_k$  is a Gaussian random noise variable of zero mean and unit variance.

## 5. RESULTS

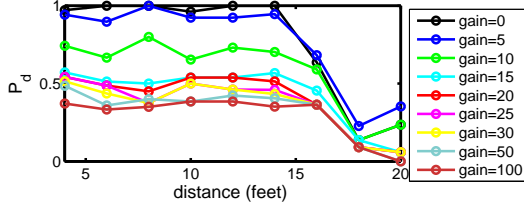

(a) Probability of detection

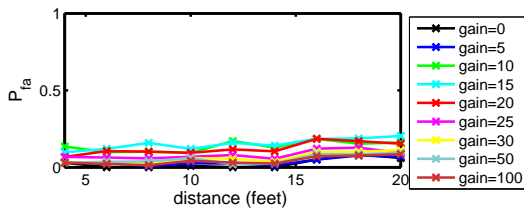

(b) Probability of false alarm

**Fig. 7.** Detector performance

To characterize the detector performance, footstep data was collected at distances varying from 2 feet to 20 feet in steps of 2 feet from the sensor. Noise in the form of speech or wind with different gain levels was synthetically added to each set of filtered data. Probability of detection ( $P_d$ ) and probability of false alarm ( $P_{fa}$ ) as a function of distance are provided in Figure 7. Within a range of 14 feet,  $P_d$  is greater than 90% and  $P_{fa}$  is less than 20% for any level of speech/wind. The detector fails to detect footsteps if simultaneous speech is present, making the probability of detection lower

with increasing noise gain. Short duration speech is comparable to the time-span of the footstep and resulted in false alarms.

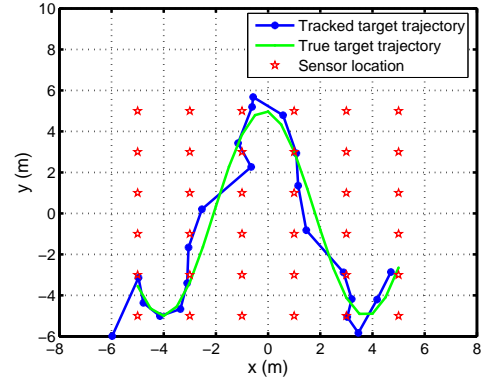

(a) Tracked trajectory

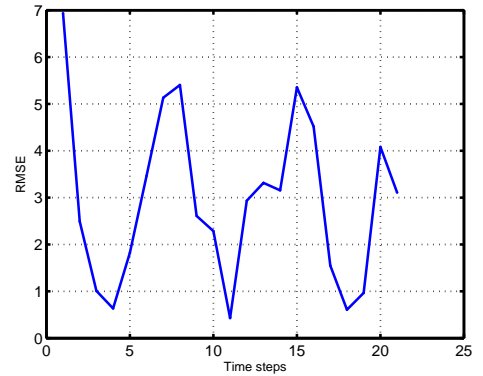

(b) RMSE plot

**Fig. 8.** Tracking result

To demonstrate the tracking performance, the simulation setup consisted of 36 motes placed in a 6x6 grid with 2 m spacing. The sensors provide acoustic energy measurements of the sound produced by the moving target. The simulated energy values were received every second duration. 21 time steps of a cosine target trajectory was tracked with 4000 particles. The root mean square error (RMSE) was computed for the tracker over 100 Monte Carlo simulation runs. The tracking results are provided in Figure 8(a). The RMSE plot is shown in Figure 8(b).

## 6. CONCLUSION

In this paper, we presented the algorithms for target detection and tracking that are applicable to perimeter security systems. This has several advantages. The low cost and low power consumption and minimum installation requirements of motes suit this application. In our application, the motes were placed on a regular pre-defined grid but with a good self localization

algorithm they could be randomly scattered. Computationally more intensive and sophisticated algorithms could be implemented on the motes provided some improvements on the hardware is incorporated. In addition to the deployed acoustic sensor, the motes can be equipped with other sensors like seismic, infrared and still/motion cameras.

The current algorithm is not capability of detecting a foot-step in the presence of simultaneous speech or wind noise. This limitation can be circumvented by using better hardware. The issue of scalability may be overcome by multi-hop data transmission techniques and clustering of nodes. With the advances in high speed low power hardware architecture and improved sensor technology coupled with sophisticated statistical signal processing algorithms these applications offer enhancements in operational efficiency for security systems.

## Acknowledgments

We would like to thank our advisors Prof. Antonia Papandreou-Suppappola and Prof. Darryl Morrell for their guidance and supervision.

## 7. REFERENCES

- [1] J. Weese K. Harman, "E-field technology update," *38th Annual 2004 International Carnahan Conference on Security Technology*, pp. 61–68, October 2004.
- [2] R.C. Luo, S.Y. Lin, and K.L. Su, "A multiagent multisensor based security system for intelligent building," *IEEE Conference on Multisensor Fusion and Integration for Intelligent Systems*, pp. 311–316, 2003.
- [3] "Closed circuit television," [http://en.wikipedia.org/wiki/Closed-circuit\\_television](http://en.wikipedia.org/wiki/Closed-circuit_television).
- [4] B. Griffiths, "Developments in and applications of fibre optic intrusion detection sensors," *IEEE proceedings*, 1995.
- [5] "Perimeter protection importance, solutions, problems secure your perimeter for safety," [http://www.fiber-fence.com/perimeter\\_protection.asp](http://www.fiber-fence.com/perimeter_protection.asp).
- [6] M.S. Arulampalam, S. Maskell, N. Gordon, and T. Clapp, "A tutorial on particle filters for online non-linear non-Gaussian Bayesian tracking," *IEEE Transactions on Signal Processing*, vol. 50, no. 2, Feb 2002.
- [7] M.S. Arulampalam, B. Ristic, and N. Gordon, *Beyond the Kalman filter : Particle Filters for Tracking Applications*, Artech House, 2004.
- [8] A. Doucet, N. de Freitas, and N. Gordon, *Sequential Monte Carlo Methods in Practice*, Springer Verlag, 2001.
- [9] B. Anderson and J. Moore, *Optimal Filtering*, Prentice-Hall, 1979.
- [10] "Crossbow technologies inc.," <http://www.xbow.com/>.
- [11] "Intel motes," <http://www.intel.com/research/exploratory/motes.htm>.
- [12] K.M.Masica, "Analysis of emerging mote technology as a distributed sensor platform," *Lawrence Livermore National Laboratory*, pp. 68–69, 2004.
- [13] C. Vossberg, "Prototyping a wireless sensor network for acoustic target detection and tracking," M.S. thesis, Arizona State University, 2006.
- [14] J.U.Cho, S.H. Jin, X.D.Pham, J.W.Jeon, J.Byun, and H.Kang, "A real-time object tracking system using a particle filter," *IEEE/RSJ International Conference on Intelligent Robots and Systems*.
- [15] X.Xu and B.Li, "Adaptive rao-blackwellized particle filter and its evaluation for tracking in surveillance," *IEEE Transactions on Image Processing*, vol. 16, pp. 838 – 849, 2007.
- [16] Y.Zhu, Liu, and Z.Qiang, "Tracking human hand motion using genetic particle filter," *IEEE International Conference on Systems, Man and Cybernetics*, vol. 6, pp. 4942 – 4947, 2006.
- [17] Z.Shah and R.A.Malaney, "Particle filters and position tracking in wi-fi networks," *IEEE 63rd Vehicular Technology Conference*, vol. 2, pp. 613 – 617, 2006.
- [18] "Work on motes," <http://fulton.asu.edu/~lasr/motes/>.
- [19] F. Hlawatsch and G.F. Boudreaux-Bartles, "Linear and quadratic time-frequency signal representations," *IEEE SP magazine*, pp. 21–67, 1992.
- [20] L.Cohen, "Time-frequency distribution - a review," *IEEE proceedings*, July.
- [21] "Pascal's triangle," [http://en.wikipedia.org/wiki/Pascal's\\_triangle](http://en.wikipedia.org/wiki/Pascal's_triangle).
- [22] A. Swain, "Characterization of acoustic sensor motes for target tracking in wireless sensor networks," M.S. thesis, Arizona State University, 2006.